

verilux[®]
The Healthy Lighting Company™

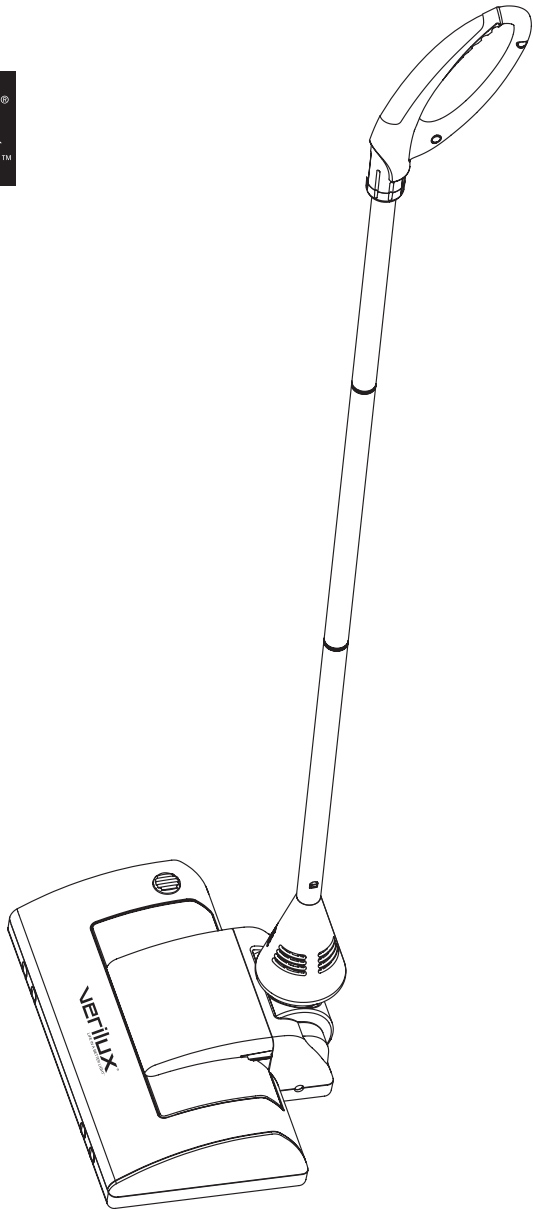

Sanitizing Sweeper

with Verilux[®] SaniClean Lightwave Technology™

VH02



Dear Customer,

Thank you for purchasing the Verilux® Sanitizing Sweeper with SaniClean Lightwave Technology.™ You have received an innovative and quality manufactured product, backed by a one-year limited warranty. As a Verilux® customer, your satisfaction means everything to us. We look forward to serving you now and in the future.

Many other healthy lighting products are available through our catalog and online. Visit us on the web at www.Verilux.com to request a free catalog and learn more about all our quality Verilux® products, or call our toll-free number 1-888-544-4865.

Have a Bright Day!

A handwritten signature in black ink that reads "Nicholas Harmon". The signature is written in a cursive, flowing style.

Nicholas Harmon
President and CEO

IMPORTANT SAFETY INSTRUCTIONS

We appreciate you purchasing the Sanitizing Sweeper. Before using this product, please study this manual carefully to avoid any damage to the product or to you.

- Before using, please make sure the Sweeper is securely assembled.
- The Sweeper is not intended for use by children under 8 years of age.
- Do not use flammable or combustible liquids to clean the sweeper.
- The sweeper contains a rechargeable 4.8v Ni-MH battery. Please be sure to fully charge the battery for 12 hours prior to initial use and do not leave on charger for longer than 24 hours. Old batteries should be disposed of properly and never incinerated.
- Do not use the Sweeper to clean any burning or heated materials such as cigarettes, matches, ash or any flammable liquids, such as gasoline. Use on dry surfaces only.
- Keep fingers, hair, all other body parts and clothes away from rotating cleaning brushes.
- Do not use wet hands to touch battery or battery parts directly.
- Do not use the sweeper to clean shag carpet, wet floors or rough stone or concrete surfaces. The Sweeper should be used on hardwood and low-pile carpeted floors only.
- Before cleaning the dust from the dust bin, turn off the power.
- The Sweeper employs a powerful UV-C light source to kill household germs. The Sweeper should never be turned over when turned on and the light allowed to shine in eyes or on exposed skin.

SAVE THESE INSTRUCTIONS

DANGER

Ultraviolet (UVC) Radiation Hazard.

Any exposure will cause significant eye damage and may cause skin damage.

Do not look into UV light source. Wear UV eye and skin protection.

WARNING POTENTIAL MOLD SPORE RELEASE

Application of UV-C light to existing mold growth can cause respiratory irritation and allergic symptoms. Do not use UV-C light where active mold growth exists. Remove active mold growth from surfaces prior to exposure.

ASSEMBLY INSTRUCTIONS

Before assembling, please review all instructions.

1. Carefully remove all parts from the box and make sure all parts listed on the spare parts illustration are included. If any parts are missing, please contact Verilux at 1-888-544-4865.
2. Assemble 3 shaft sections (A) according to the illustration and make sure sections are joined together securely.

NOTE: The middle shaft section can be taken out when using Sweeper on stairs or on upholstery

3. Remove Part B from the handle assembly by pulling it apart (photo 1). Fully insert knurled end of shaft into handle assembly (photo 2). Slide Part B over shaft, line up arrows on part B and handle assembly (photo 3), and push together against handle assembly to lock shaft to the handle.
4. Your Sweeper was shipped with the “smart” battery disconnected from the Sweeper. Prior to charging the battery, turn the Sweeper upside down, slide the battery compartment door toward the rear of the Sweeper (see arrow on cover door), insert the male connection of the battery wire into the female connection of the Sweeper.
5. To charge the battery, plug included AC Adapter/Battery Charger into the charger socket on the side of the base of the Sweeper and charge initially for 12 hours before using. When charged, carefully remove the battery charger cable prior to using. Never leave the charger connected for longer than 24 hours at a time.
6. Turn on power switch and begin to use on proper surfaces.

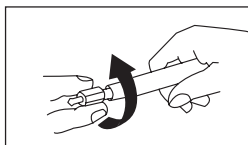
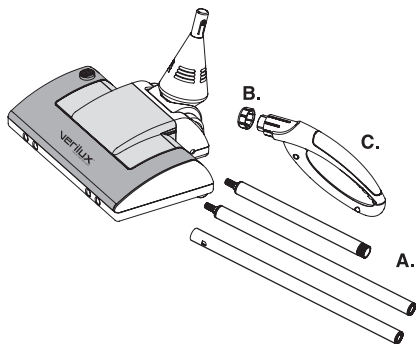

3

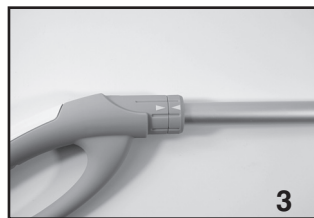
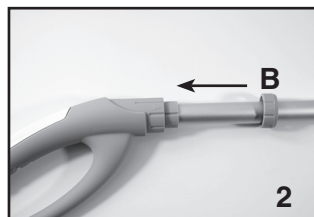
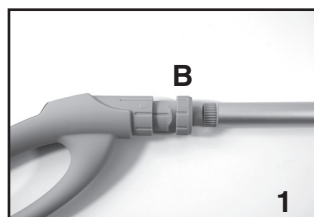

ASSEMBLY INSTRUCTIONS

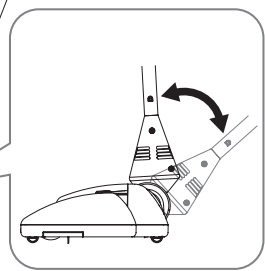
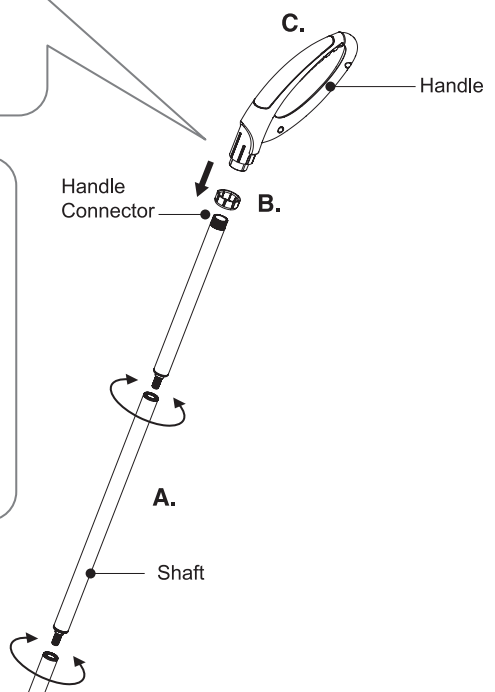
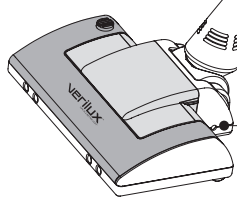
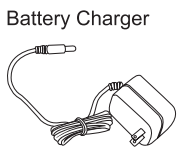
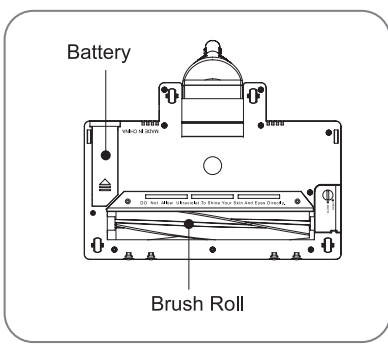
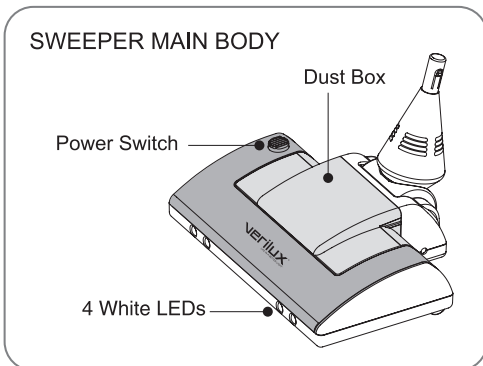
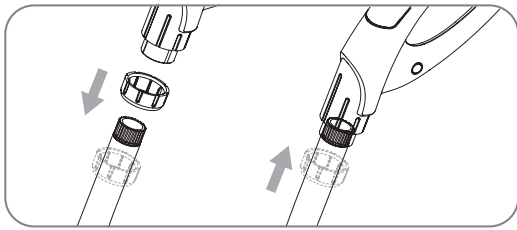

Charger Socket

OPERATION

- Gently step on the power switch once to activate the Sweeper and the UV-C light function.
- Press switch second time to switch off.

ATTENTION: This Unit features a safety cut-off switch for the UV-C light. When the wheels come off the floor, the light automatically switches off. Do not allow the UV-C Light to come into direct contact with the eyes or skin.

2 Step Switch	
1st Step	SWEEP / STERILIZE / LIGHT UP
2nd Step	TURN OFF

CHARGING INSTRUCTIONS

- Connect battery charger to the Sweeper unit. Plug the charger into the electric outlet located on your household wall to start charging.
- Sweeper may be charged after each use for not more than 24 hours or damage to batteries might occur.
- You can notice the power condition according to the LED indicator light located on the charger.
- When charging the Sweeper, sweeping and sterilizing functions are inoperable.

Recharge Status	
RED LIGHT	Initial Charging Phase
ORANGE LIGHT	Final Charging Phase
GREEN LIGHT	Fully charged—remove charger

REPLACING THE BATTERY

- Turn off the power.
- Turn the Sweeper upside down and open the battery cover according to the illustration shown.
- Pull out the battery pack and disconnect it from the power wire.
- Insert a new battery pack and reconnect the power wire.
- Replace the battery cover and recharge the sweeper to get it ready to operate.

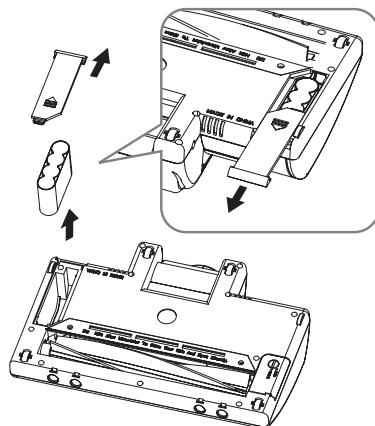

ATTENTION: New batteries require an initial 12 hour charge before using. After that, recharge until green light appears. Never charge for more than 24 hours or damage to the batteries may occur.

EMPTYING THE DUST BIN AND CLEANING THE DUST FILTER

ATTENTION: Please ensure that the power is off when performing any maintenance operation.

1. To turn off the power, step gently on the switch.
2. Leave the Sweeper on floor and carefully pull upward to remove the dust bin and filter.
3. Remove and gently clean the filter cover. Carefully empty dust bin into trash receptacle.

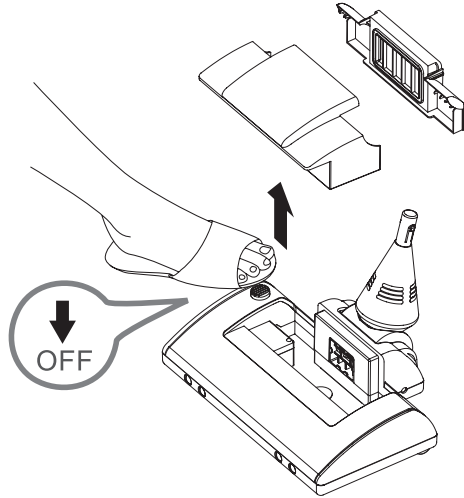

CLEANING BRUSH ROLL

1. Use screwdriver (not included) to open the brush cover.
2. Carefully pull brush roller up and move transmission belt to the outside, allowing the brush roller to be lifted out for cleaning.
3. Remove hair and fiber from the brush roll.
4. Reassemble unit as before.

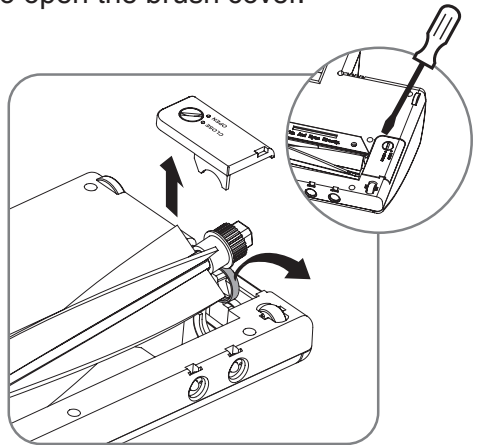

One-Year Limited Warranty

ATTENTION! ONCE OPENED, PLEASE **DO NOT** RETURN THIS PRODUCT TO THE STORE WHERE IT WAS PURCHASED FOR REPAIR OR REPLACEMENT!

Many questions may be answered by visiting www.Verilux.com, or you may call our customer service department at 1-888-544-4865.

This limited warranty is provided by:

Verilux, Inc., 340 Mad River Park, Waitsfield, VT 05673

Verilux® warrants this product to be free from defects in material and workmanship for a period of one year from the date of the original retail purchase. Rechargeable batteries are not included in this warranty. During the limited warranty period, Verilux, Inc. will, at its option, repair or replace defective parts of this product, at no charge to the customer, subject to the following limitations. This limited warranty does not include any postage, freight, insurance or delivery fees. This warranty does not cover damage, defect or failure caused by or resulting from accident, external destruction, alteration, modification, abuse, misuse, or misapplication of this product.

If, during the first year of ownership, this product fails to operate properly, it should be returned as specified below:

Please pack the defective product in its original protective packing and box, with a copy of your sales receipt, along with \$6.95 (check or money order to cover shipping and handling), and send to:

For U.S. Postal Service Only:

Verilux Warranty

Service Center, c/o WTB

P.O. Box 119, West Redding, CT 06896

For Fed Ex & UPS Only:

Verilux Warranty

Service Center, c/o WTB

32 Henry Street, Bldg 17A, Bethel, CT 06801

Please allow 4-6 weeks before you receive the repaired or replaced product.

ATTENTION: When returning a product, be aware that damage during shipping is the responsibility of the purchaser and will void any warranty claim. We recommend that you insure the shipment by shipper when returning this product or any parts. Be sure to return product in original packaging.

Due to ongoing improvements, actual product may have slight variations from the product described in this manual.

Please visit our web site at: www.Verilux.com

verilux®
LIFE IN A BETTER LIGHT®

340 Mad River Park, Waitsfield, VT 05673